

TOOLS REQUIRED FOR ASSEMBLY:
 ADJUSTABLE WRENCH OR 10MM & 11MM WRENCH
 LARGE PHILLIPS HEAD SCREWDRIVER

HARDWARE

USED IN STEP 2 & 5



FOUR (4)
M6X20 THREADED STUDS



FOUR (4)
M6 LOCK NUTS

USED IN STEP 3



FOUR (4)
M6X16 FLAT PHILLIPS
HEAD SCREWS

SIDE TABLE SCREWS



EIGHT (8)
SELF-TAPPING
PHILLIPS HEAD
SCREWS

USED IN STEP 4



FOUR (4)
M6 ACORN NUTS

COMPONENTS

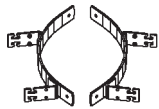

TWO (2)
SIDE SUPPORTS

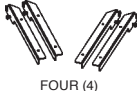

FOUR (4)
SHELF BRACKETS

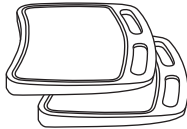

TWO (2)
SIDE SHELVES

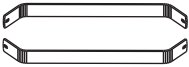

TWO (2)
STABILIZERS



ONE (1)
CROSS BRACE

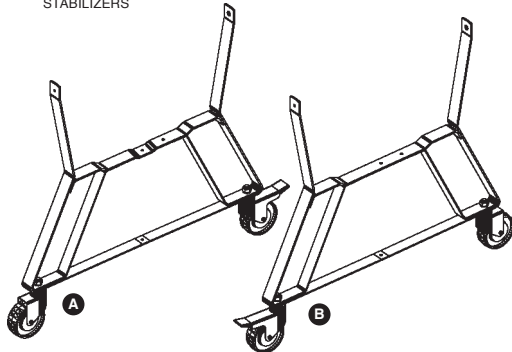

TWO (2)
BASE SUPPORTS

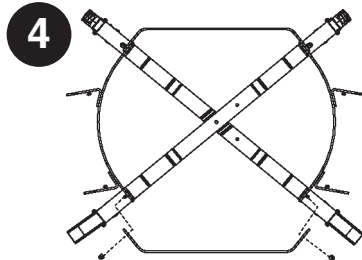
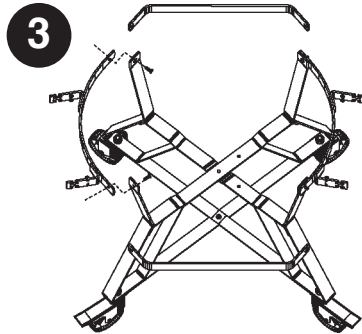
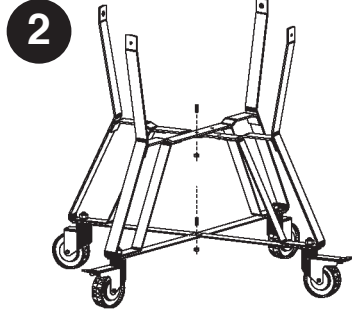
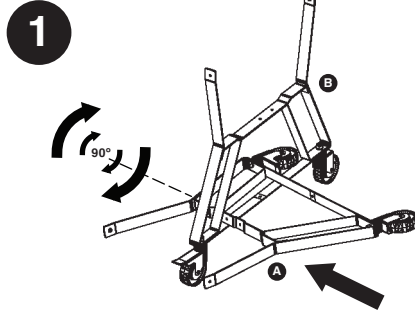

Note: Locking casters should face forward on the long side.

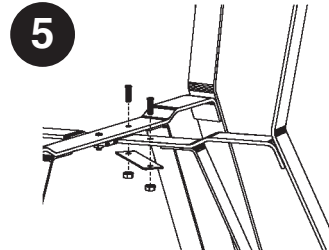

ASSEMBLY INSTRUCTIONS

Remove all parts from the packaging and compare to the parts list. Refer to the numbered drawings (left) for assembly guidance.

- 1 Holding base support B on the floor insert base support A through B as shown. Twist base support A into the upright position as shown in step 2.
- 2 Align the center holes as shown. Insert the 2 M6X20 threaded studs through the top of the center holes and attach 2 M6 lock nuts from below the assembly. FINGER TIGHTEN ONLY AT THIS TIME
- 3 Insert 4 M6X16 phillips head screws through the holes in the base support uprights with the threads facing outward of the assembly. Align the 2 side supports over the fasteners.
- 4 Align one of the stabilizers over the fasteners and attach 2 M6 acorn nuts. Repeat for the opposite side of the assembly. FINGER TIGHTEN ONLY AT THIS TIME
- 5 Insert 2 M6X20 threaded studs in each hole toward the center of the base supports, threads facing downward. Align the cross brace from below and fasten 2 M6 lock nuts to the screws. Tighten ALL fasteners with an adjustable or 10MM & 11MM wrench and phillips head screwdriver.

SIDE SHELF BRACKET ASSEMBLY

OVAL XL AIO

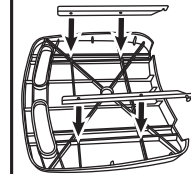

Fasten 4 self-tapping screws per shelf in outer mounting holes.

OVAL JR & LG AIO

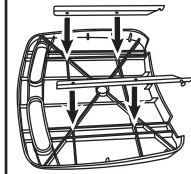

Fasten 4 self-tapping screws per shelf in inner mounting holes.

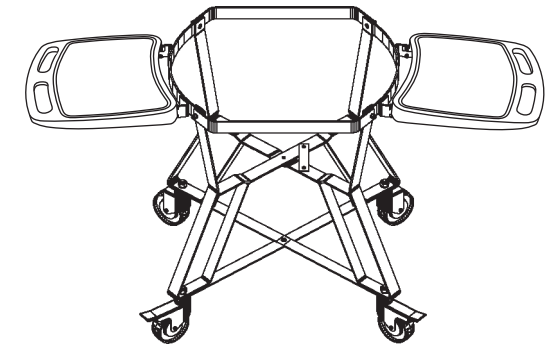

COMPLETED ASSEMBLY